

Building connections that last™

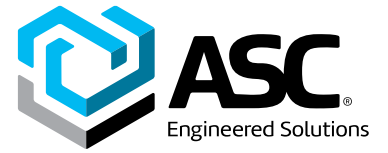

ABZ 400 Series

Elite Seal Double Offset High Performance Butterfly Valves Datasheet



Elite Seal Double Offset High Performance Butterfly Valves ABZ 400 Series

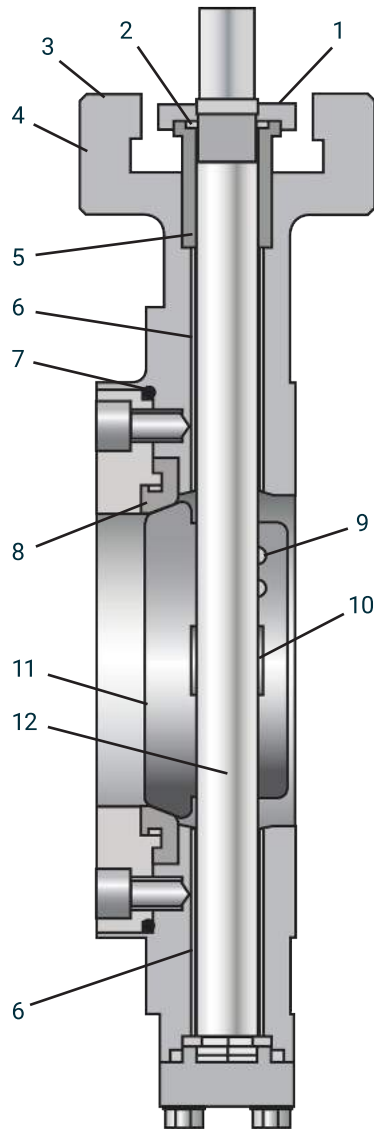

Feature & Benefits

1. Underneath Drawn Gland Packing – Allows for ease of user adjustment to the gland nuts and direct mounting of actuation
2. Stem Retention System – Provides positive stem retention above the packing
3. Mounting Flange – Designed to direct mount actuation for ease of installation and cost saving
4. Body is available in Wafer and Lug
5. Packing – PTFE is a cup and cone system
6. Bearings – Made of 316 stainless steel sleeves impregnated with RTFE to ensure long service life
7. Seat Retainer – The heavy-duty retainer plate and cap screws provide a full rated bi-directional dead end service valve. The seat retainer seal prevents leakage to the atmosphere past the retainer plate and body
8. Seat – Utilizes a solid soft seat with a unique channel design. This advanced design provides a bi-directional interference and pressure-assisted seal. This achieves maximum seal at low or high pressures while preventing the seat from bending or deflecting downstream
9. Disc Taper Pins – Pins are offset from the center of the stem, which places them in compression rather than in shear. This gives them a yield point greater than the stem itself. Pins are welded in place after final assembly and testing
10. Integrally Cast Disc Position Stop – Machined position stop in the body locates the disc in the seat to achieve maximum seat and seal life
11. Disc – Cast from 316 Stainless Steel (CF8M – A351), and engineered to allow for quick release from the seat. The disc has a heavy duty low cavitation cross section connection to the stem. This results in lower torques and smoother operations
12. Stem – Manufactured of high strength 17-4 PH Stainless Steel to provide maximum strength and stability for high torque applications

Elite Seal Double Offset High Performance Butterfly Valves

ABZ 400 Series



411 is a 150 Class Wafer
431 is a 300 Class Wafer



412 is a 150 Class Lug
432 is a 300 Class Lug

Main Materials

Body

ASME Class 150, ASME Class 300
Carbon Steel (A216-WCB)
316 SS (A351-CF8M)

Disc

316 SS (A351-CF8M)

Stem

17-4 PH SS (A564-630)

Seat

MRTFE
RMTFE + Inconel 718 (Fire-Safe)

Shaft Bearing

316 SS + RTFE Impregnated

Packing Seal

PTFE
Graphite (Fire-Safe)
Additional materials available upon request.

Standard Production Range

	ASME Class 150	ASME Class 300
Rating – PSI CWP	285	740
Size – Inch	2" - 24"	2" - 24"
Design Specifications	API 609, Category B	
Testing	API 598	
Face to Face Specifications	ASME B16.10 / API 609	
End Flange Specifications	ASME B16.5: CLASS 150, 300 JIS B2210: 10K, 16K, 20K DIN ISO: PN10, PN16, PN25, PN40	
Connection	Wafer / Lugged	
Actuator – Manual	Lever Handle Worm Gear Operator	
Actuator – Automated	Electric Motor Pneumatic Double Acting Pneumatic Spring Return	

Seat Material and Rating

Seat Material	Rating
MRTFE	Bubble Tight
RMTFE + Inconel 718	Bubble Tight (pre-fire)

Elite Seal Double Offset High Performance Butterfly Valves

ABZ 400 Series



Materials of Construction

Item No.	Name	Materials		No Req'd
		Trim 050	Trim 052	
1	Body	A216-WCB	A351-CF8M	1
2	Seat	MRTFE		1
3	Disc	A351-CF8M		1
4	Stem	17-4 PH		1
5	Seat Retainer	A216-WCB	A351-CF8M	1
6	Gland Flange	A216-WCB	A351-CF8M	1
7	End Cap	A216-WCB	A351-CF8M	1
8	Packing Gland	316		1
9	Packing Stack	PTFE		1 Set
10	Packing Retainer	316		1
11	O-Ring	PTFE		1
12	Upper Bearing	316 + PTFE		1 Set
13	Retainer Ring	316		1
14	Cap Packing	PTFE		2
15	Adjustment Washer	PTFE		1
16	Spring Washer	316		4
17	Cap Bolt	316		4
18	Taper Pin	316		2
19	Gland Bolt	316		2
20	Spring Washer	316		2
21	Gland Nut	316		2
22	Retainer Bolt	316		1 Set

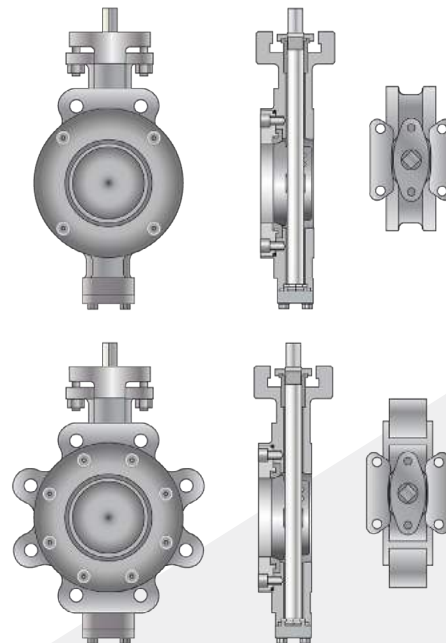
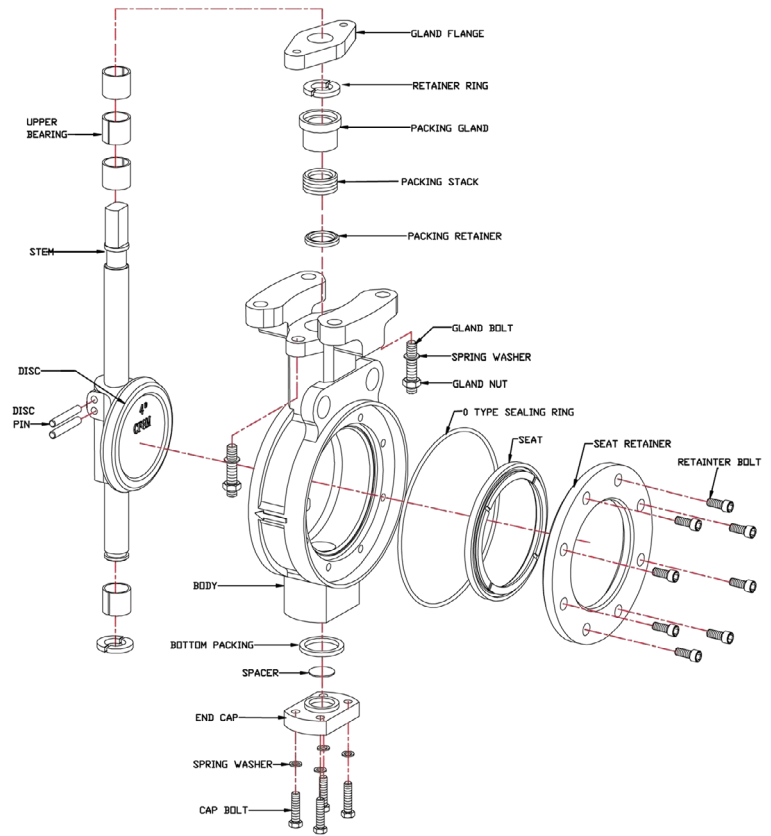

Elite Seal Double Offset High Performance Butterfly Valves

ABZ 400 Series

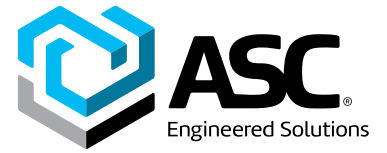

How to order Elite Butterfly Valves

Example: 12" 412 052 NSF GO

A 12" ASME Class 150 single flange lug-design, with cast CF8M stainless steel body, cast CF8M stainless steel disc, 17-4 PH SS stem, MRTFE seat, PTFE shaft seals, NSF, and gear operators, is: 12" 412 052 NSF GO.

12"		412		052	NSF GO	
Size		Series		Trim	Variation / Option	
2"	10"	ASME Class 150		XXX ↑	<blank>	Bare stem
2.5"	12"	411	Wafer		NSF	NSF certified ‡
3"	14"	412	Lug		NACE	NACE
4"	18"	ASME Class 300			SF	Silicone free
5"	18"	431	Wafer		HDL	Handle
6"	20"	432	Lug		GO	Gear operator
8"	24"				‡ Use with Trim Code 052.	

Trim Code	Seat Type	Body Material	Disc Material	Stem Material	Seat Material	Stem Packing	Trim Code
050	Resilient	WCB	CF8M (316 SS)	17-4 PH SS	MRTFE	PTFE	050
052		CF8M (316 SS)					052
408	Fire-Safe	WCB	CF8M (316 SS)	17-4 PH SS	RMTFE + INCONEL 718	GRAPHITE	408
409		CF8M (316 SS)					409

Note: Responsibility for proper selection, use and maintenance of any product remains solely with the purchaser and end user. We reserve the right to modify or improve the designs or specifications of any product at any time without notice.



Gear Dimensions																Gear Weight		
Valve Size	Operator	Tap Holes	B.C.	R	N	ØP	ØI	J	J1	S	S1	ØL	M	ØW	X		Y	Z
2in - 6in	G6	(4) 3/8-16 x .55	3.25	.62	7	.203	.63	5.04	5.76	2.31	1.13	4.21	9.11	5.91	1.97	8.35	2.09	10 lbs
8in - 12in	G12	(4) 3/8-16 x .79 (4) 1/2-13 x .79	3.25 5	1.16	10.07	.260	.748	6.50	6.50	2.61	1.22	5.91	13.02	11.81	1.94	10.86	2.44	19 lbs

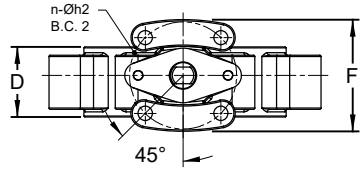

Top View

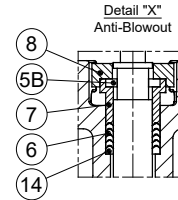
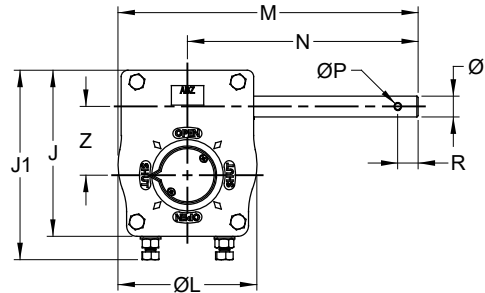

Detail "X"
Anti-Blowout

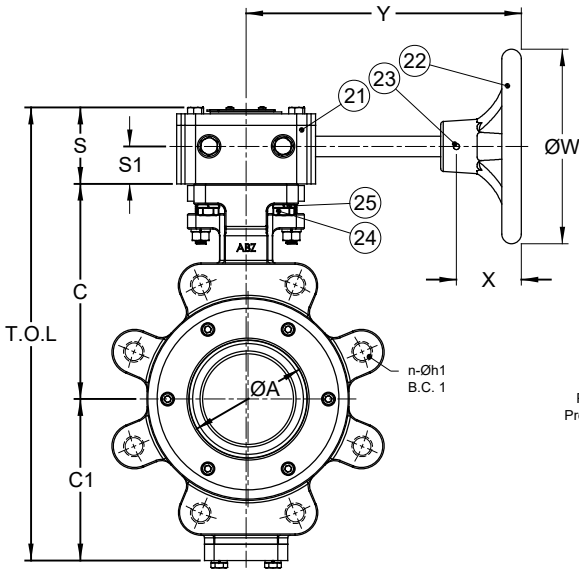

Flow View

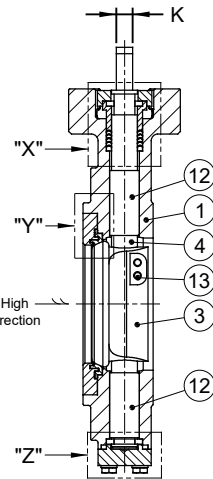

Section View

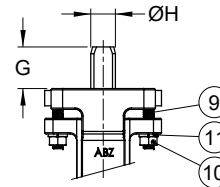

2" thru 8" Stem

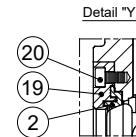

Detail "Y"

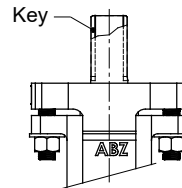

10" thru 12" Stem

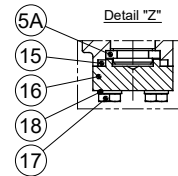

Detail "Z"

Parts Schedule			
Item No.	Name	Material	No. Req'd
1	Body	A216-WCB	1
2	Seat Ring	MRTFE	1
3	Disc	A351-CF8M	1
4	Stem	A564-630 (17-4 PH)	1
5A	Retainer Ring	A276-316	1
5B	Anti-Blowout Ring	A276-316	1
6	Packing	PTFE	1 Set
7	Packing Gland	316 Stainless Steel	1
8	Gland Flange	A216-WCB	1
9	Gland Bolt	316 Stainless Steel	2
10	Nut	316 Stainless Steel	2
11	Spring Washer	316 Stainless Steel	2
12	Bush Bearing	316 Stainless Steel + PTFE	2
13	Disc Pin	316 Stainless Steel	1 Set
14	Packing Retainer	316 Stainless Steel	1
15	Cap Packing	PTFE	1
16	Cap	A351-CF8M	1
17	Cap Bolt	316 Stainless Steel	1 Set
18	Spring Washer	316 Stainless Steel	1 Set
19	Seat Retainer	A216-WCB	1
20	Retainer Bolt	316 Stainless Steel	1 Set
21	Gear	Cast Iron	1
22	Handwheel	Cast Iron	1
23	Roll Pin	Carbon Steel	1
24	Bolt	Zinc Plated Steel	1 Set
25	Spring Washer	Zinc Plated Steel	1 Set

Notes:

- Design : ANSI B16.34 & API 609
- Gasket Contact Surface : Finish 125~250 AARH
- Face to Face Dimension :
3in, 4in, 6in, 8in, 10in, & 12in : API 609 Category B
2in, 2.5in, & 5in : ISO 5752 Short
- Flange Connection : ANSI B16.5 Class 150
- Test Pressure (psig) : API 598.
 - Shell Test :
- Test Medium : Water at room temp.
- Test Pressure : 450 psi
 - Seat Test :
- Test Medium : Water at room temp.
- Test Pressure : 325 psi
- Installation: Bi-Directional / Double Dead End Service
- Valve Rating: Preferred Direction 285 psi
Non-preferred Direction 285 psi
Dead End Service: Preferred Direction 285 psi
Non-preferred Direction 285 psi
Vacuum Service: Vacuum on non-preferred low pressure side.
- Valves manufactured prior to 2013 have only one keyway.

Valve Dimensions

Valve Size		ØA	C	C1	D	F	G	ØH	K	Key (Qty. 2)	T.O.L	Valve Weight	Mounting Base			Flange Dimension		
Inch	MM												B.C. 2	n	Øh2	B.C. 1	n	Øh1
2	50	1.89	5.08	3.68	1.69	3.26	1.26	.551	.374	—	11.14	11 lbs	3.25	4	.43	4.75	4	5/8-11unc
2-1/2	65	2.36	5.16	3.84	1.85	3.26	1.26	.626	.437	—	11.38	13 lbs	3.25	4	.43	5.50	4	5/8-11unc
3	80	2.74	5.51	4.04	1.89	3.26	1.26	.626	.437	—	11.93	15 lbs	3.25	4	.43	6.00	4	5/8-11unc
4	100	3.59	6.54	4.90	2.13	3.39	1.26	.748	.500	—	13.82	24 lbs	3.25	4	.43	7.50	8	5/8-11unc
5	125	4.61	6.97	5.33	2.24	3.39	1.26	.748	.500	—	14.68	31 lbs	3.25	4	.43	8.50	8	3/4-10unc
6	150	5.51	7.36	5.73	2.24	3.39	1.26	.748	.500	—	15.47	37 lbs	3.25	4	.43	9.50	8	3/4-10unc
8	200	7.42	8.78	6.83	2.52	4.92	1.26	.874	.626	—	18.22	59 lbs	5.00	4	.55	11.75	8	3/4-10unc
10	250	9.33	10.43	8.40	2.80	4.92	2.05	1.126	—	.25 x .25	21.44	90 lbs	5.00	4	.55	14.25	12	7/8-9unc
12	300	11.22	11.89	9.74	3.19	5.00	2.05	1.126	—	.25 x .25	24.24	131 lbs	5.00	4	.55	17.00	12	7/8-9unc

ASC ABZ Valves & Controls
An ASC Engineered Solution

Title:			Unit
Elite Double Offset Butterfly Valve			inch
Series 412 (CL 150) - Trim 050 - Lug Type			Projection
DWG No.			Template
2in-12in 412-050-G Gear			ARO
Date	Drawn	Checked	Revision
2022-1.11	Tp	Tp	0
Dimensions are subject to change without notice.			