



**2" - 12" R/S VALVE NRS FLANGED ENDS  
GENERAL DIMENSIONS**

KENNEDY VALVE MODEL KS-FW

Complies with applicable requirements of AWWA C509

\*Face to face dimensions conform to ASME B16.10

8561ASS W/HANDWHEEL  
8561ANSS W/NUT  
8701ASS W/POST PLATE (3-12")

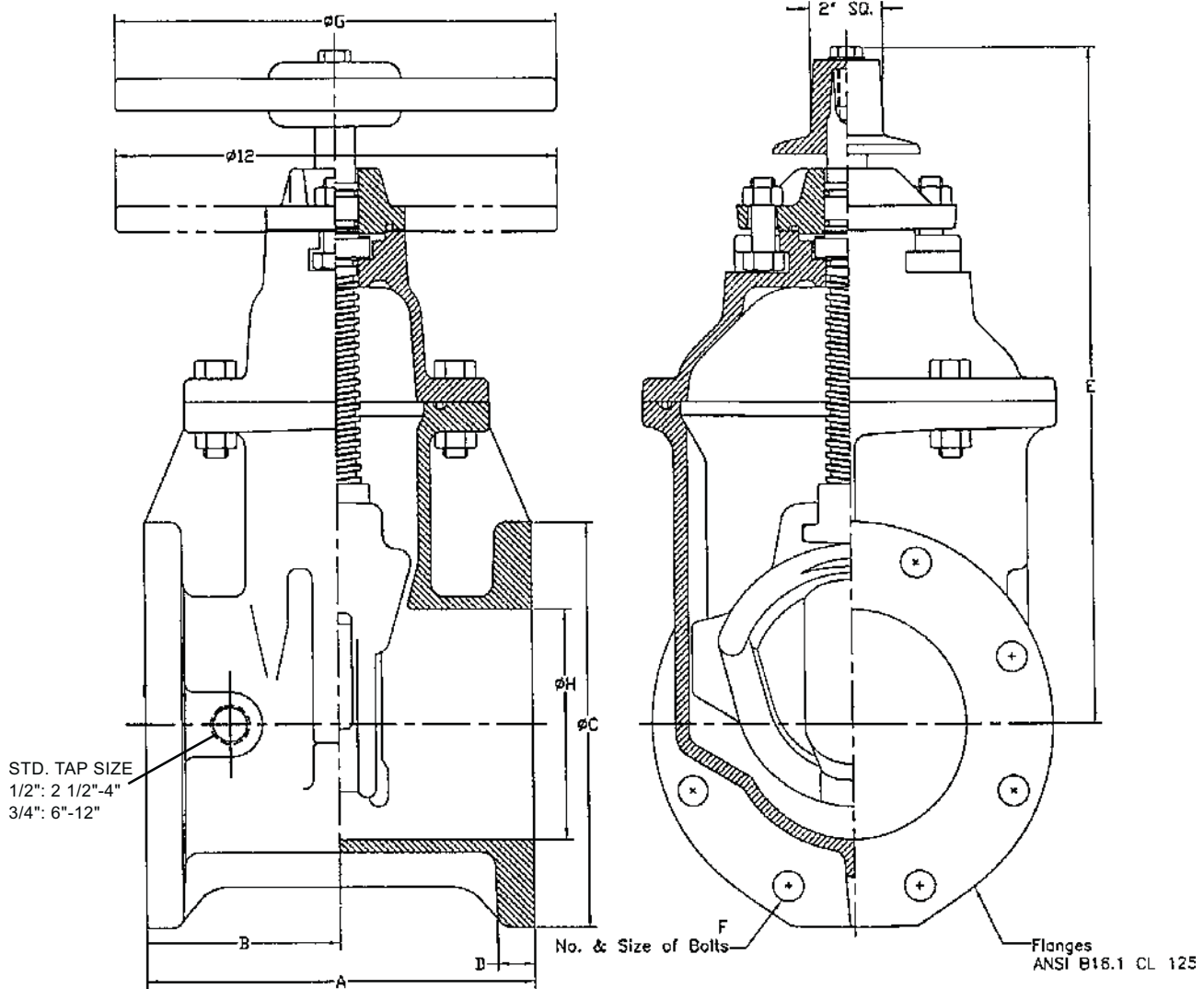

ALL FLANGE VALVES TAPPED & PLUGGED @ POSITION "A"

VALVE SIZE	* A	B	C	D	E	F	G	H	WEIGHT*
2	7	3 1/2	6	11/16	10 7/8	4 5/8	7 1/4	2	41
2 1/2	7 1/2	3 3/4	7	11/16	11 3/8	4 5/8	7 1/4	2 1/2	49
3	8	4	7 1/2	3/4	12 3/8	4 5/8	10	3	62
4	9	4 1/2	9	15/16	14 3/4	8 5/8	10	4 1/4	99
6	10 1/2	5 1/4	11	1	19	8 3/4	12	6 1/4	142
8	11 1/2	5 3/4	13 1/2	1 1/8	22 1/2	8 3/4	14	8 1/4	239
10	13	6 1/2	16	1 3/16	26 1/2	12 7/8	18	10 1/4	408
12	14	7	19	1 1/4	30	12 7/8	18	12 1/4	554

NOTE: ADD 16 LBS. FOR INDICATOR POST PLATE (3"-12" ONLY)