

Stainless Steel Gate Valves

FIGURES
117 • 117F

Class 150 • OS&Y • Solid or Flexible Wedge Disc

Figure 117

Raised Face, Flanged Ends, Solid Wedge Disc

Figure 117F

Raised Face, Flanged Ends, Flexible Wedge Disc

Size Range:

½ through 24 inches

Design Features:

- Bolted Bonnet
- Rising Stem
- Integral Seat
- Retained Gasket
- MSS SP-42
- API 603

Industry Standards

End Flanges	ASME B16.5
Wall Section	ASME B16.34
Face-to-Face	ASME B16.10
Pressure-Temp Ratings	ASME B16.34
Design	API 603
Testing	API 598

Materials of Construction

1	Body	ASTM A351 CF8M
2	Bonnet	ASTM A351 CF8M
3	Disc	ASTM A351 CF8M
4	Stem	ASTM A276 T316
5	Handwheel	ASTM A536
6	Gasket	PTFE
7	Gland Flange	ASTM A351 CF8
8	Gland	ASTM A276 T304
9	Packing	PTFE
10	Stem Nut	ASTM A536
11	Handwheel Nut	ASTM A276 T304
12	Bonnet Bolt Nut	ASTM A194 GR 8
13	Bonnet Bolt	ASTM A193 GR B8
14	Eyebolt Pin	ASTM A276 T304
15	Eyebolt	ASTM A193 GR B8
16	Eyebolt Nut	ASTM A194 GR 8
17	ID Tag	Aluminum
18	Washer	ASTM A536
19	Grease Fitting	304 SS
20	Set Screw	Steel

Dimensions and Weights

Valve Size	Weight (lbs)	Dimensions (inches)		
		A	B (open)	C
½	7.4	4.25	8.1	3.9
¾	8.3	4.63	8.5	3.9
1	10.0	5.00	9.1	3.9
1½	18.0	6.50	11.0	5.5
2	27.0	7.00	12.6	6.3
2½	37.5	7.50	15.1	6.3
3	46.3	8.00	16.7	7.9
4	75.0	9.00	20.9	9.8
6	128.0	10.50	28.7	12.4
8	216.1	11.50	36.9	14.0
10	291.1	13.00	43.9	14.0
12	436.6	14.00	51.9	15.7
14	703.4	15.00	58.5	17.7
16	1018.7	16.00	66.9	19.7
18	1190.7	17.00	74.8	22.0
20	1631.7	18.00	82.5	28.0
24	2434.3	20.00	97.4	31.5

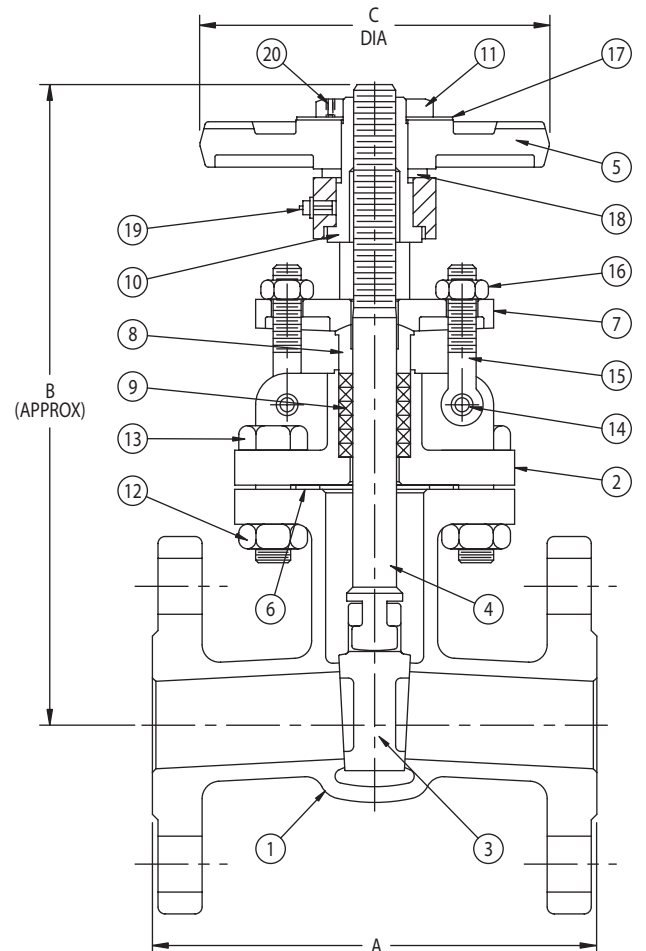

Fig. 117

